



New Doosan Warehouse Equipment

Elektric Pallet Truck with fold-away driver platform

LEDH 20 MP

LOAD CAPACITY 2,000 kg

Design features

- Powerful and economical per AC controlled drive contactorless electronics
- Strong drive motor for high drive speed with optimal traction
- Distinguished ramp aptitude
- Robust, stabil 5-point chassis with small truck dimension
- Load-Lift without battery weight – high energy efficiency

Operating elements

- Multifunctional, ergonomically handles
- Controller for smooth ones drive forward and backwards
- Rocket buttons for hoisting and lowering

Standard equipment

- Drive wheel Vulkollan
- Load wheels Vulkollan
- Battery change to the side
- Spring-loaded operator platform

Options

- Various fork length
- Battery 24v from 180 Ah to 350 Ah
- Automatic speed-reduction in curves



Manufacturer specification and design features

Characteristic features	Manufacturer type designation			LEDH 20 MP
	Drive			Electric
	Operator type			Pedestrian
	Load capacity	Q	t	2.0
	Load centre distance	C	mm	600
	Load distance	X	mm	950
Weight	Service weight		kg	530
	Axle loading, laden front/rear		kg	1127 / 1703
	Axle loading, unladen front/rear		kg	656 / 174
Tyres, Chassis	Tyres			Vulkollan
	Drive Wheel		mm	ø230x80
	Load Wheel		mm	ø85 / 78
	Support Wheel		mm	ø125x50
	Tread, front		mm	358
	Tread, rear		mm	468
Dimensions	Lift	h3	mm	120
	Height of Tiller in drive position	h14	mm	1225
	Height, lowered	h13	mm	85
	Overall length	l1	mm	1875
	Length to face of forks	l2	mm	729
	Overall width	b1	mm	700
	Fork dimensions	e / l	mm	160 / 1150
	Distance between fork-arms	b5	mm	520
	Ground clearance, centre of wheelbase	m2	mm	40
	Aisle width for pallets, 800x1200 mm, along	Ast	mm	2125
	Turning radius	Wa	mm	1675
Performance Dates	Travel speed, laden / unladen		km/h	8 / 9.5
	Travel speed, walking		km/h	5
	turn silent runing speed – Option		km/h	6
	Gradeability, laden / unladen		%	6 / 8
	Service brake			Magnetic
Electric-Engine	AC - Drive motor		kW	2.5
	DC - Lift motor		kW	2.2
	Battery acc. to DIN 43535 A / B / C / no			DIN B
	Battery voltage / nominal capacity	K5	V / Ah	24 / 360
	Battery weight		kg	300
	Impuls control for drive			impuls

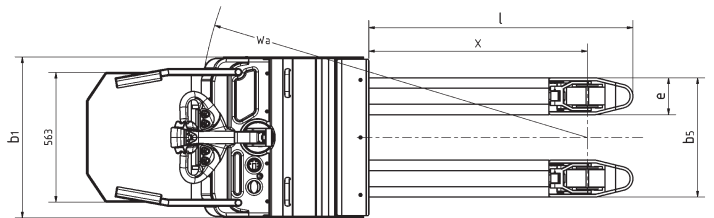
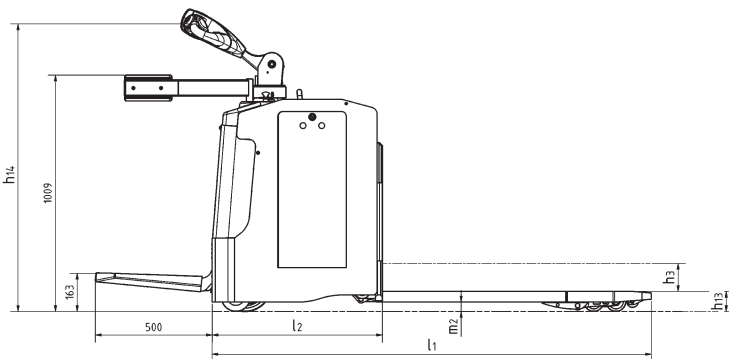

Technical modifications are subject to alteration without notice .

LEDH20MP (Jan.2010)



European Office: Europark Nord 36, B-9100 Sint Niklaas
 Tel: +32 37600987
 Fax: +49 37600989
 Website: www.doosaneurope.com

