



Electric Pallet Trucks

LEDH 18/LEDH20/LEDH 22

1,800kg to 2,200kg Capacity

The all new Doosan LEDH Series offers you

The best solution...
for your material handling!

Design Features

- Powerful AC drive motor providing high speed for use in warehouses and on ramps
- Low energy consumption and easy maintenance
- Narrow aisle width
- Great manoeuvrability with small turning radius

Operating Elements

- Multifunctional, ergonomical handles
- Turtle mode for precise operations in small areas

Standard Equipment

- AC controlled drive contactorless electronics
- Single Vulkollan load wheels
- Large Vulkollan drive tyre

Options

- Various fork dimensions (length and width)
- Cold store model (down to -30°C)
- Multifunctional display
- Stainless steel models for food industry



Technical Specifications

Description			LEDH18	LEDH20	LEDH22
Load capacity	Q	kg	1800	2000	2200
Load centre	c	mm	600	600	600
Closed height when lowered	h_{13}	mm	85	85	85
Lift height	h_3	mm	205	205	205
Handle height of tiller when vertical	h_{14}	mm	1260	1260	1260
Overall length	L	mm	1680	1680	1680
Overall width	B	mm	660	660	660
Leading structure length	L_2	mm	490	490	490
Wheel base	y	mm	1340	1340	1340
Load wheel position	RTA	mm	995	995	995
Fork length	l	mm	1190	1190	1190
Fork width	e	mm	160	160	160
Dimension across forks	b_5	mm	520	520	520
Turn Radius	RWa	mm	1490	1490	1490
Empty weight (without battery)		kg	300	300	300
Aisle width (800x1200 lengthwise)	Ast	mm	1890	1890	1890
Battery: Capacity		Ah	160-250	160-250	160-250
Voltage		V	24	24	24
Tank LBH 610x200x510..610mm	24V2EPzH	160..250Ah	•	•	•
Drive motor output	n/V/kW		1/24/1,0	1/24/1,0	1/24/1,0
Drive control	Impulse		AC	AC	AC
Lift motor output at 15 % ED	n/V/kW		1/24/1,2	1/24/1,2	1/24/1,2

Product and specifications are subject to improvement and change without notice

• = on request

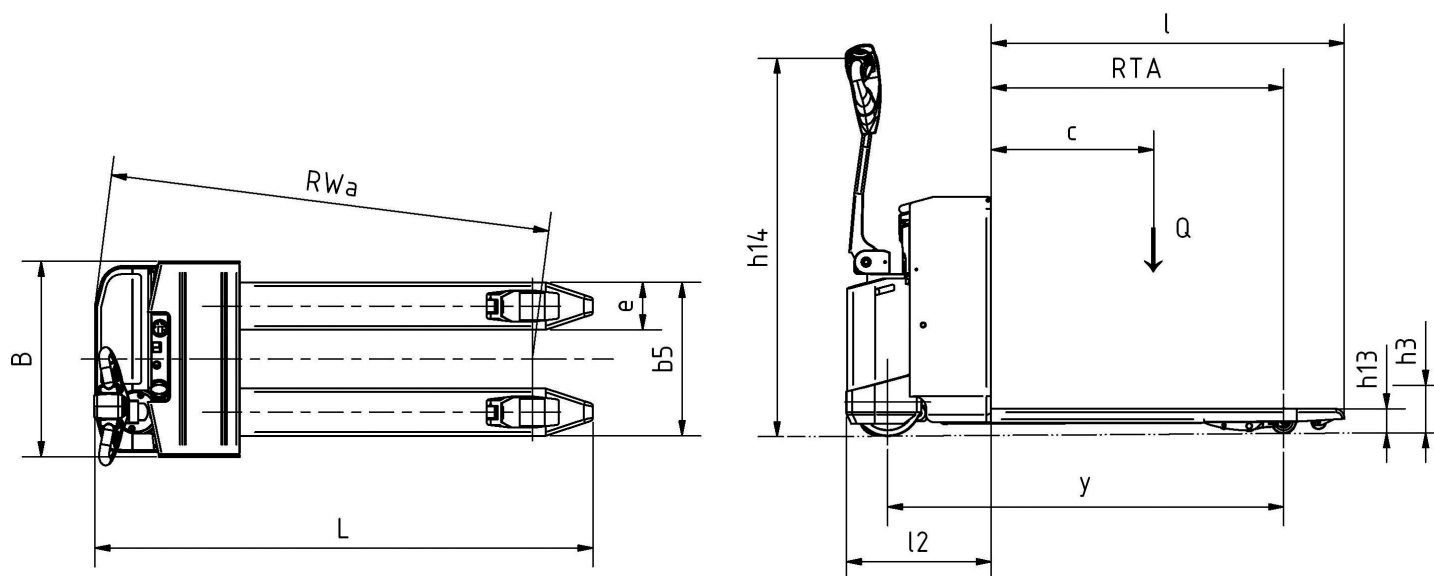

DLE LEDH (Nov.2012)



European Office: Europark Noord 36, 9100 Sint-Niklaas, Belgium
 Tel: +3237600987
 Fax: +3237600989
 Web site: <http://www.doosaneurope.com>



New Doosan Warehouse Equipment

Elektric Pallet Truck

LEDH 40 + LEDH 50

LOAD CAPACITY 4,000 kg or 5000kg

Design features

- Powerfull and economical per AC controlled drive contactorless electronics
- Strong drive motor for a optimal traction
- Robust, stabil 5-point chassis with small truck dimension

Operating Elements

- Multifunctional, ergonomical handles
- Controller for smooth ones drive forward and backwards

Standard Equipment

- Drive wheel Vulkollan
- Load wheels Vulkollan

Options

- Various fork length
- Battery 24v 4 EPzS up to 360 Ah

Made in Germany



Technical Spezifikation

Manufacturer's type designation			LEDH 40	LEDH 50
Load capacity	Q	kg	4000	5000
Load centre distance	c	mm	600	600
Height, lowered	h13	mm	90	95
lifting height	h3	mm	215	215
Height of Tiller in drive position	h14	mm	1350	1350
Overall length	L	mm	1945	1945
Overall width	B	mm	690	690
Length to face of forkes	l2	mm	755	755
wheel base	y	mm	1445	1445
Load Wheel position	RTA	mm	865	865
Fork length	l	mm	1190	1190
Fork width	e	mm	200	200
Distance over fork-arms	b5	mm	580	580
Turning radius	RWa	mm	1630	1630
Weight (without battery)	m	kg	600	600
Aisle width for pallets, 800x1200 mm,along	Ast	mm	2170	2170
Battery Capacity		Ah	160-320	160-320
Battery voltage / nominal capacity		V	24	24
Battery acc. to DIN 43535 A / B / C / no	24V4EPzS	160..320Ah	.	.
AC - Drive motor	n/V/kW		1/24/2,0	1/24/2,0
drive steering	Impuls		AC	AC
DC - Lift motor	n/V/kW		1/24/2,2	1/24/2,2

technical modifications are subject to alteration without notice

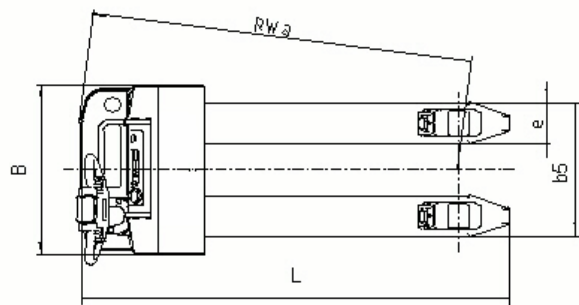
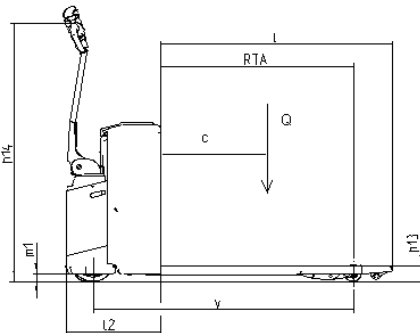

Europien Office: Europark Noord 36 B-9100 Sint Niklaas
 Tel: +3237600987
 Fax: +3237600989
 Web site: www.doosaneurope.com





Elektric Pallet Truck with center drive

LEDH 20 M

Load capacity 2,000kg

The best solution..... for your material handling

Design features

- Robust and stable 5-point chassis with small and compact dimensions
- Small width of the machine with optimal traction and excellent cornering ability
- Low energy consumption and easy maintenance

Powerful drive motor

Operating elements

- Multifunctional, ergonomical handles
- Power controller with infinitely variable adjustments
- Rocker switch for lifting and lowering
- Turtle mode for precise operations in small areas

Standard equipment

- AC controlled drive contactorless electronics
- Tandem vulkollan lead wheels
- Large vulkollan drive wheel

Optionen

- Various fork dimensions (length and width)
- Cold store version (down to 30°C)
- Battery 24V 2EPzS from 180 to 230 AH



Technical specifications

July 2012

model name			LEDH20M
load capacity	Q	kg	2000
load center	c	mm	600
Closed height when lowered	h13	mm	85
lift height	h3	mm	205
handle height of tiller when vertical	h14	mm	1260
overall length	L	mm	1690
overall width	B	mm	660
leading structure length	l2	mm	495
wheel base	y	mm	1340
load wheel position	RTA	mm	990
fork length	l	mm	1195
fork width	e	mm	160
dimension across forks	b5	mm	520
turn radius	RWa	mm	1490
empty weight (without battery)	m	kg	300
aisle width (800x1200 lengthwise)	Ast	mm	2110
battery capacity		Ah	160-230
voltage		V	24
tank LWH 610x200x510..610mm	24V2EPzS	160..230Ah	.
drive motor output	n/V/kW		1/24/1,0
drive control	Impuls		AC
lift motor output at 15% ED	n/V/kW		1/24/1,0

product and specifications are subject to improvement and change without notice

· = on request

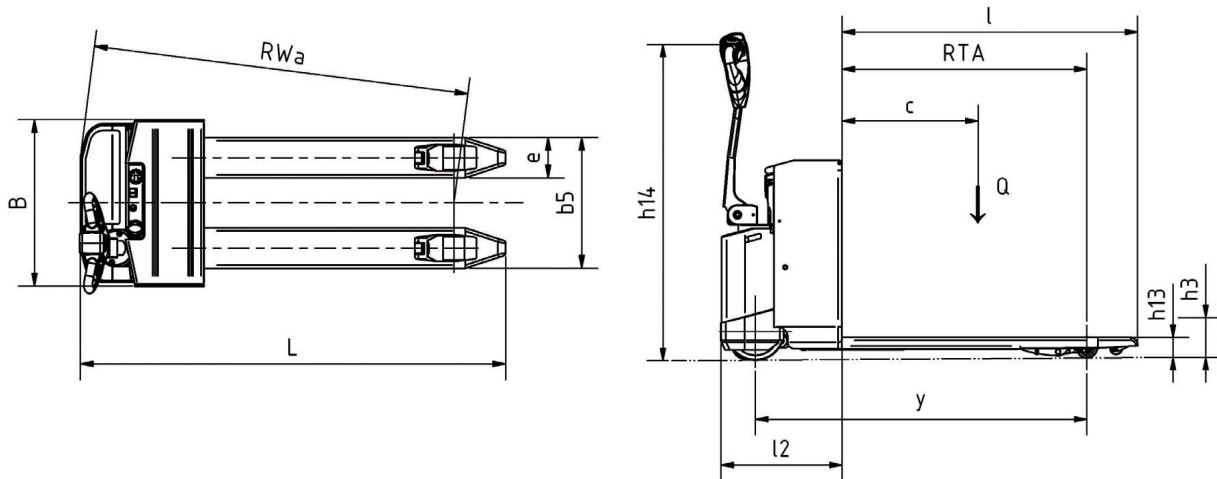

Europien Office: Europaark Noord 36A; B-9100 Sint Niklaas
Phone: +32- 3760 1643
Fax: +32-3760 0989
Web Site: <http://www.doosaneurope.com>