



*A refined fork
positioner
designed to
increase
productivity,
improve safety
and decrease
product damage.*



The fork positioner for warehousing and distribution material handling requirements.

APPLICATIONS

The 55K & 65K sideshifting fork positioners are recommended for distribution, warehousing and manufacturing operations. These high visibility fork positioners allow the operator to accurately position the forks from the driver's seat for handling a variety of pallet configurations.

FEATURES

- Cascade load backrest compatibility
- Excellent operator visibility
- No-weld installation
- Zinc plated, corrosion resistant components
- Centre mount fork carriers:
 - 55K model / 100mm suitable for 80 & 100mm forks
 - 65K model / 125mm suitable for 100 & 125mm forks

OPTIONS

- 100-125mm wide fork carriers for 55K Models
- Bolt-on pallet protector/cylinder guard combinations
- 1200 & 1500mm high load backrests
- Bronze bearings
- Bronze lower hooks
- Radio Frequency (RF) Hydraulic Control
- Non-Sideshifting (FP) units available

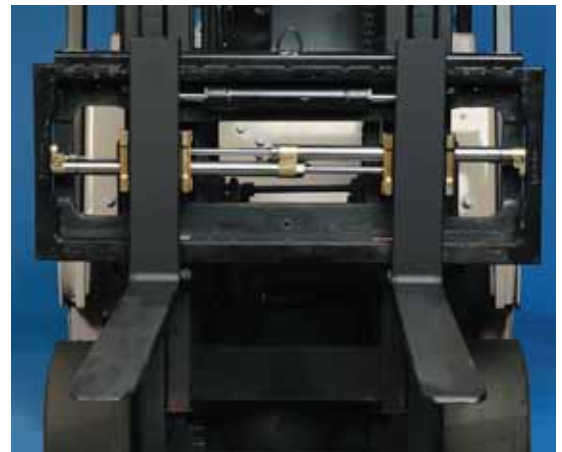

Removable fork carrier end allows forks to be easily installed. No weld-on anchor lug is required.

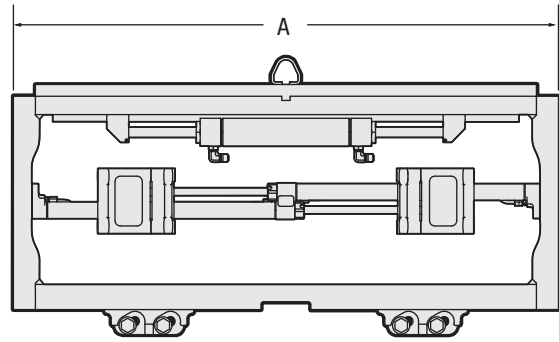
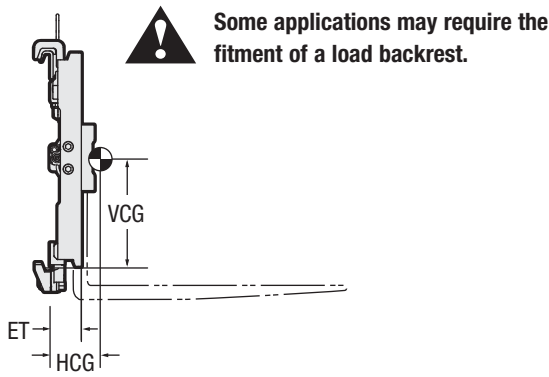

Model	Capacity @ Load Center	Load Center	Overall Width (mm)	Fork Pocket Width	Opening Range In To Out (mm)		Mounting Class ISO-2328	Min. Truck Carriage Width	Total Sideshift Available	Mass (kg)	Horizontal Center of Gravity (mm)	Vertical Center of Gravity (mm)	ET Effective Thickness (mm)
	(kg)	(mm)	A	(mm)	Min	Max		(mm)	(mm)		HCG	VCG	ET
55K-FPS-A501	2500	600	800	100	50	675	2	735	200	57	30	228	59
55K-FPS-A504	2500	600	900	100	50	775	2	895	200	61	30	226	59
55K-FPS-A506	2500	600	920	100	50	795	2	895	200	62	30	226	59
55K-FPS-A511	2500	600	980	100	50	855	2	895	200	65	30	226	59
55K-FPS-A513	2500	600	1020	100	50	895	2	895	200	66	30	226	59
55K-FPS-A514	2500	600	1040	100	50	915	2	895	200	67	30	226	59
55K-FPS-A517	2500	600	1100	100	50	975	2	975	200	70	30	226	59
55K-FPS-A520	2500	600	1150	100	50	1025	2	1040	200	72	30	226	59
65K-FPB-B517	3500	500	1100	125	50	975	3	935	200	85	31	290	64
65K-FPB-B522	3500	500	1200	125	50	1075	3	1035	200	90	31	290	64
65K-FPB-B527	3500	500	1300	125	50	1175	3	1035	200	94	31	290	64

- ▶ Forks are not included with attachment.
- ▶ 1500 mm fork maximum length.
- ▶ 55K & 65K are pre-drilled to accept the Cascade Load Backrest.
- ▶ Fork positioner function can be actuated with Radio Frequency Hydraulic Control Option.

NOTE

For frame widths wider than 1300mm refer to the Cascade "G-Series Compact" or the "F-series" Fork Positioners.

OPTIONS



Bolt-On Pallet/Cylinder Guard
provides additional protection for the pallet and cylinders.

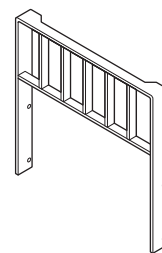

Load Backrest
Note: Cascade makes custom load backrests.



Radio Frequency Hydraulic Control
provides a simple, cost effective means to position the forks. Permits the use of a single auxiliary valve to control an additional hydraulic function.
Eliminates the need for additional hydraulic hoses or electric cables and offers a minimum of installation time.